

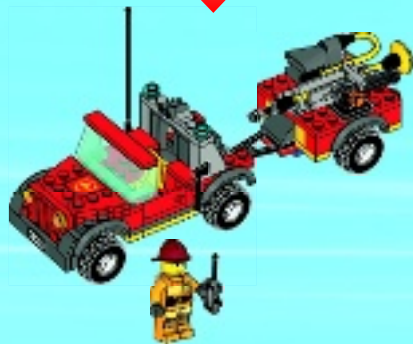

CITY

4209





1

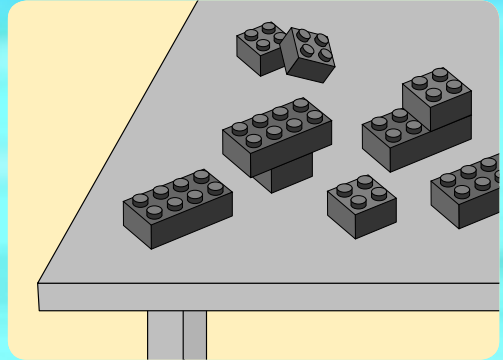
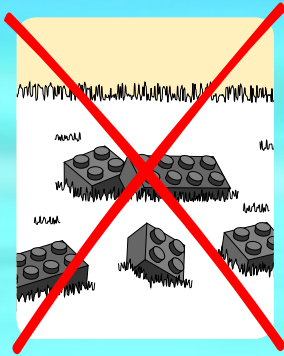

2

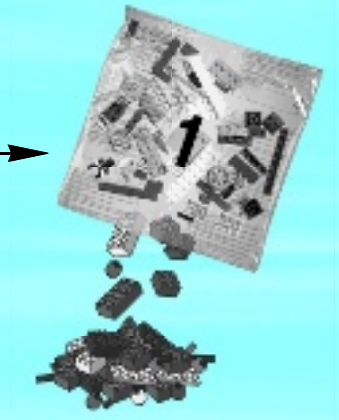



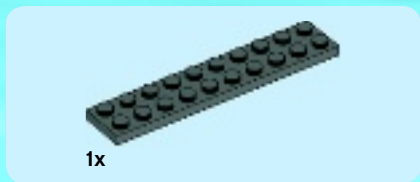

1x

1

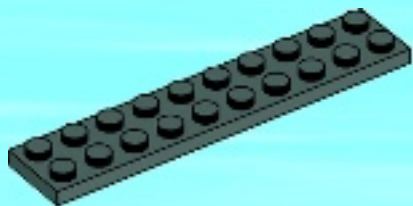

1x

2x

2

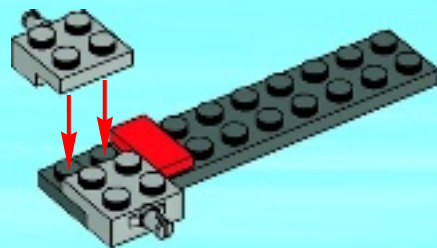



1x

3

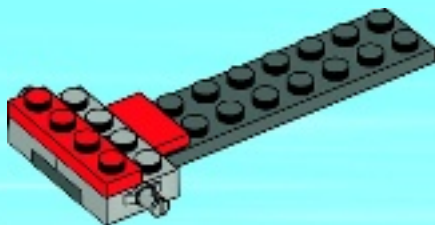

6



1x

4

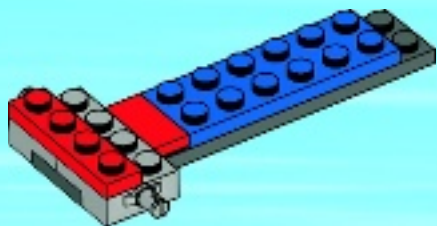

2x

5

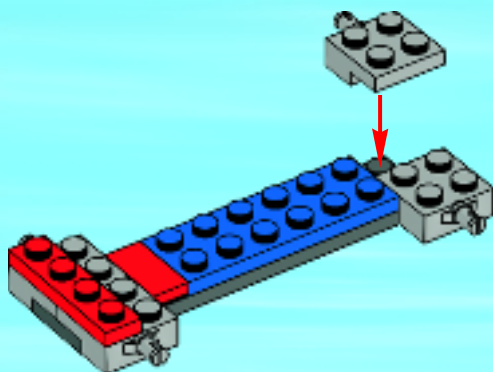

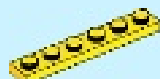

1x



1x

6

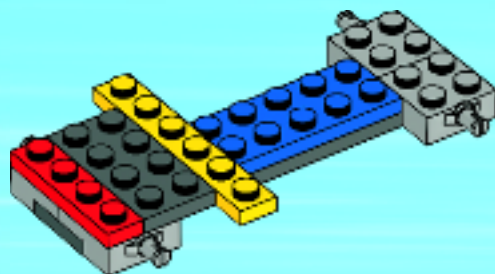



7

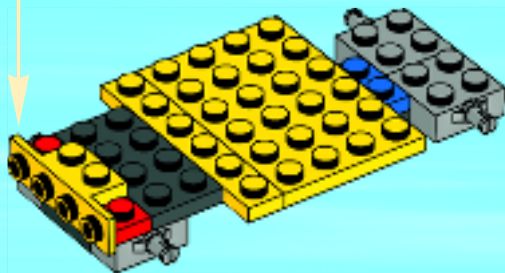

8

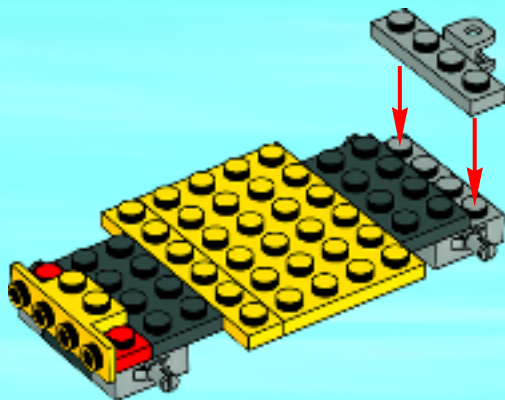



1x



1x

9

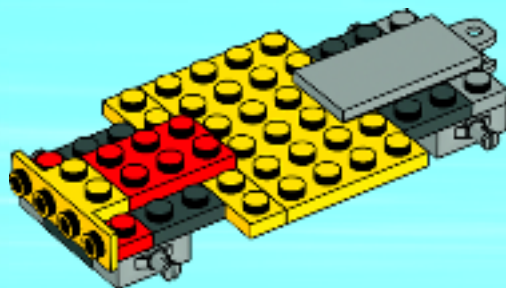

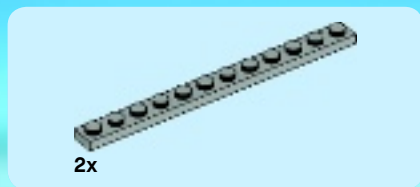

10

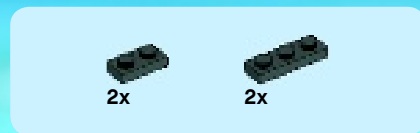
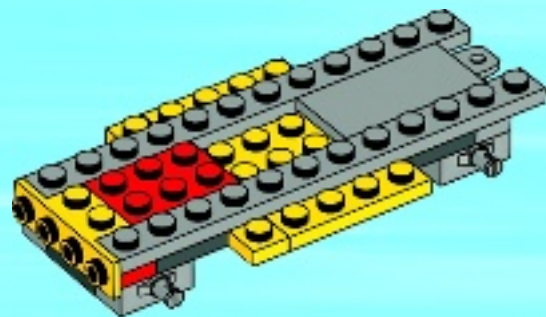

11

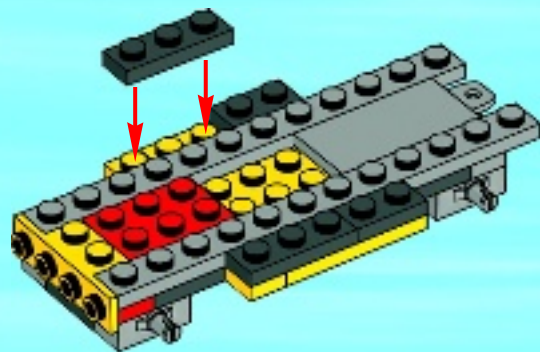



1x



1x

12

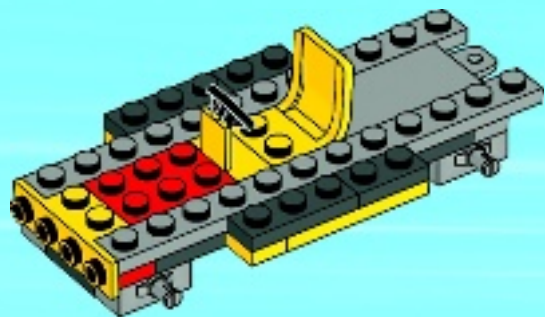

1x



2x

13

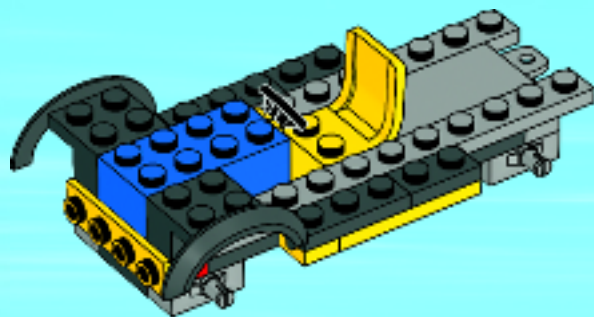



2x

14

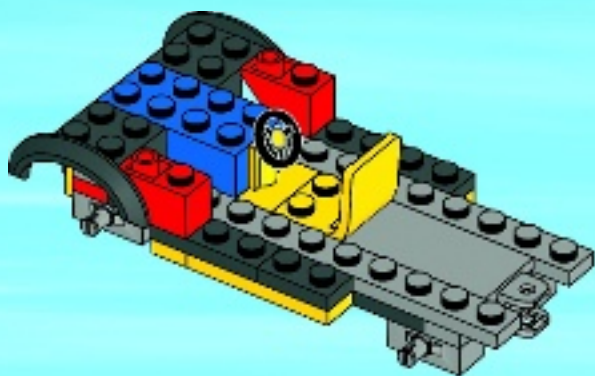



2x

16

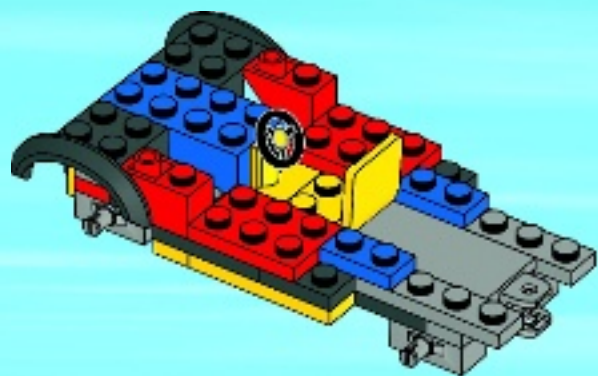

2x

17

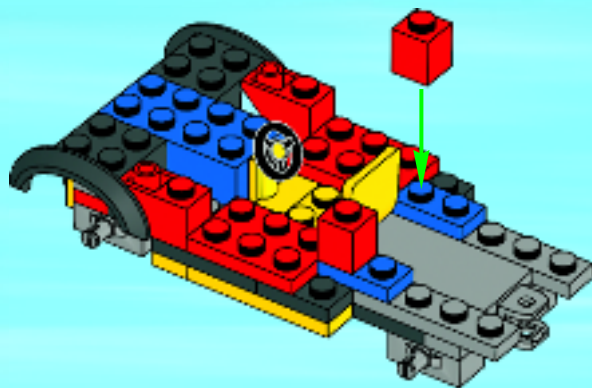



2x

19

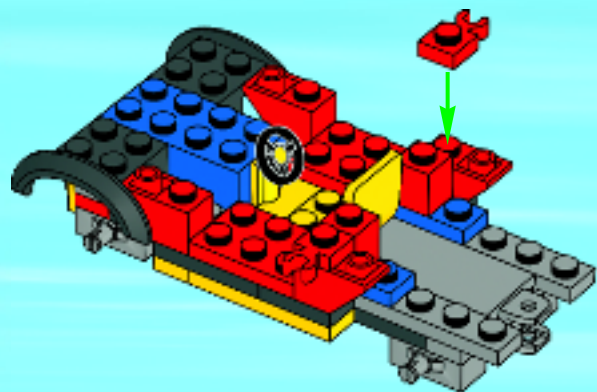

2x

20

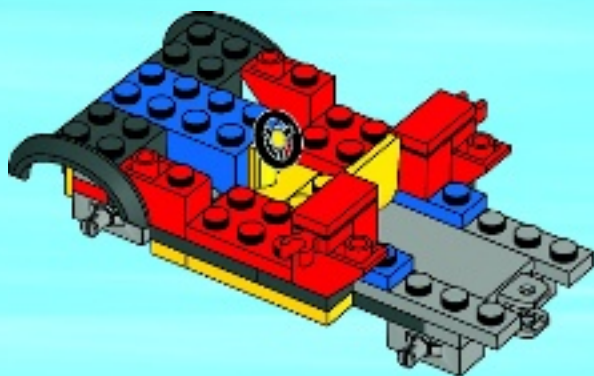



1x

21

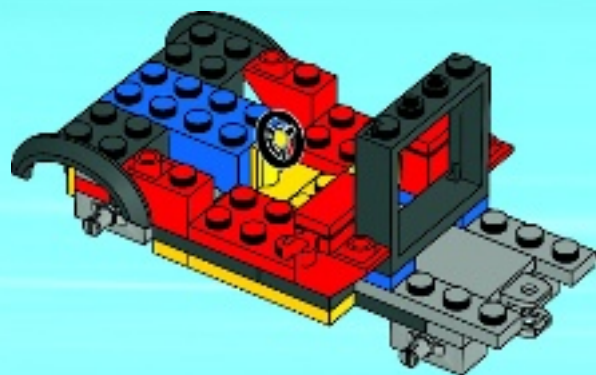

2x

22

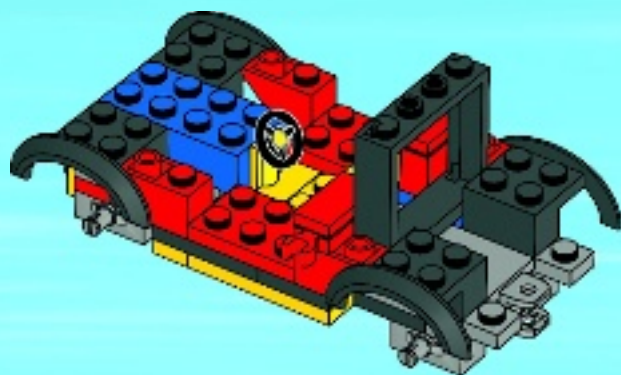



23

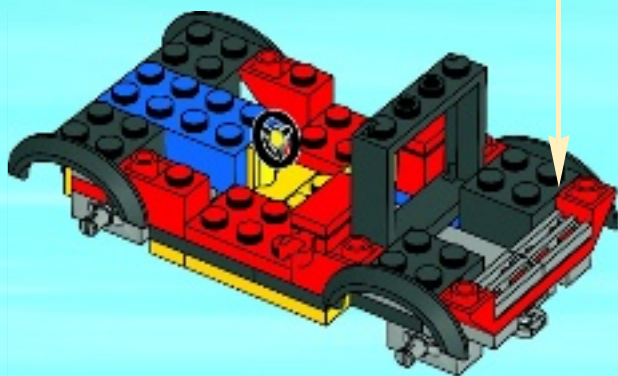
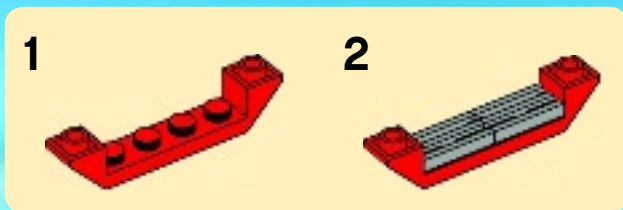



2x

24

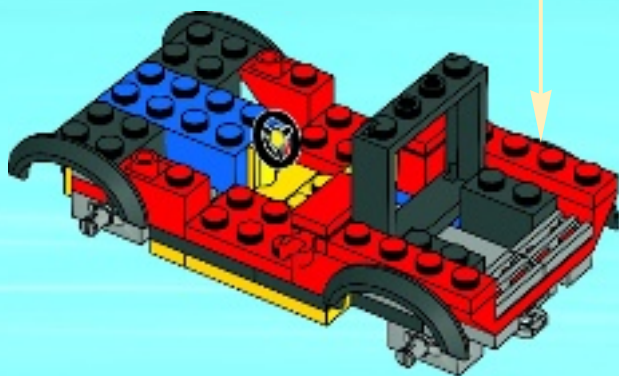
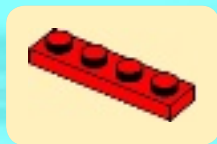



2x

25

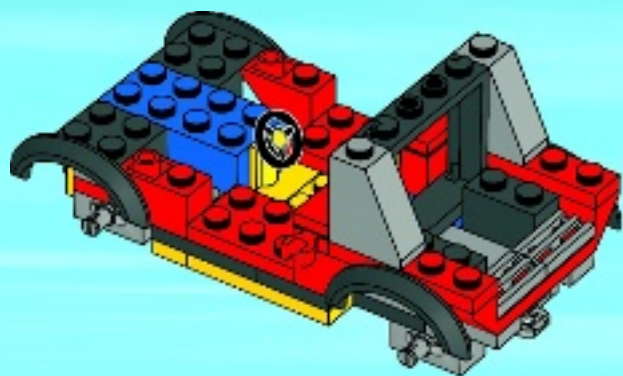

1x



1x

26

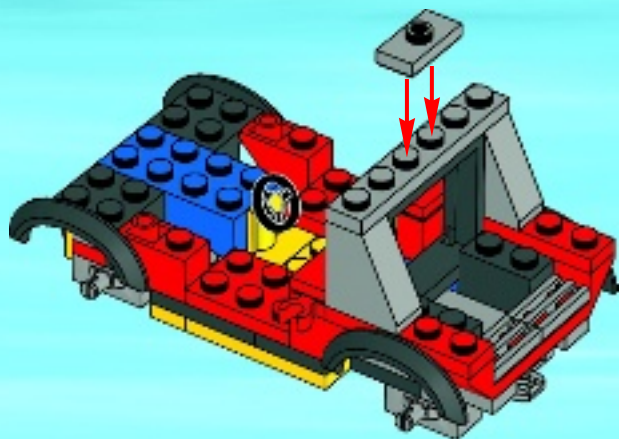



2x



1x

27

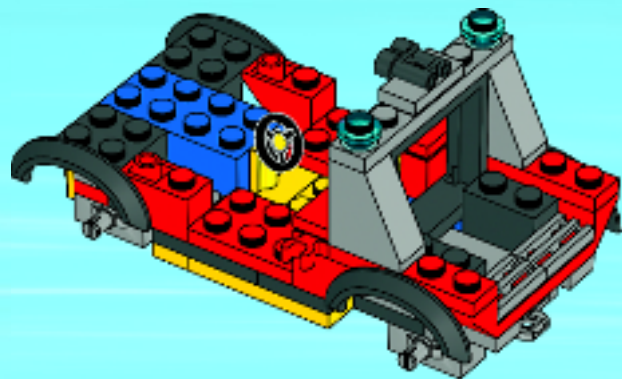



1x

28

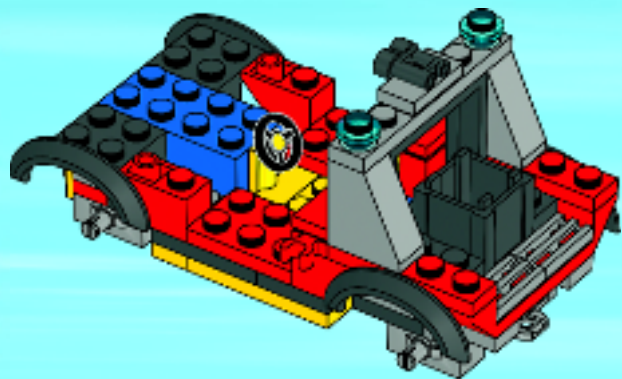

1x



1x



29

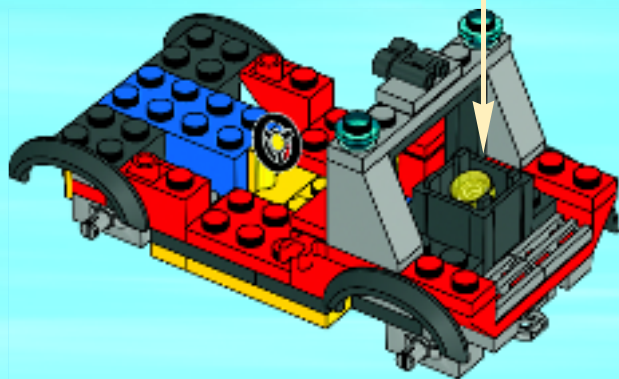



1x



1x



1x

30

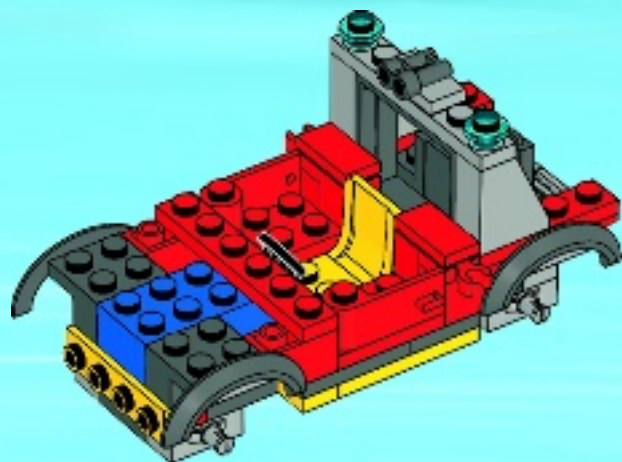



1x

31

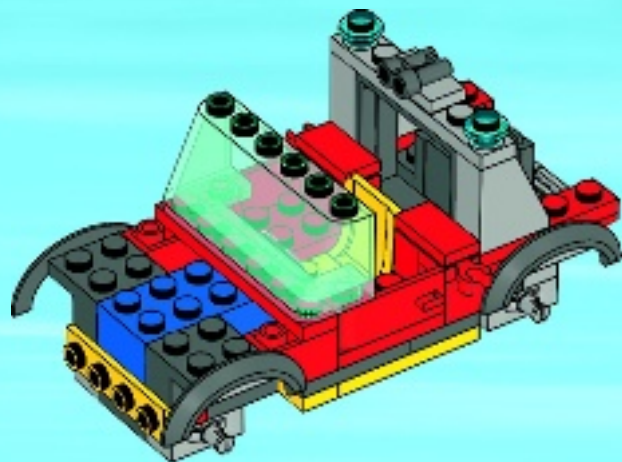

1x



1x



1x

32

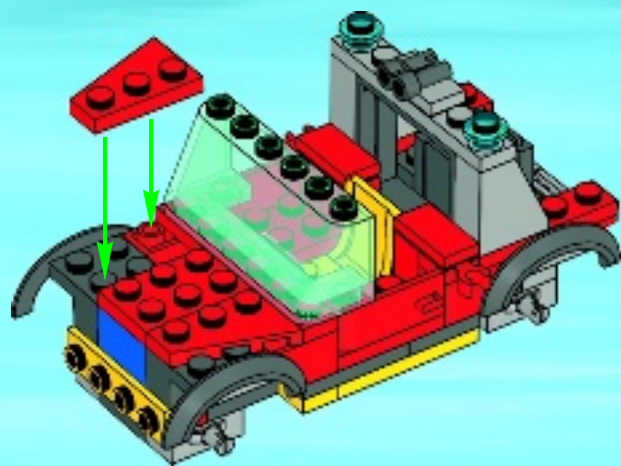



1x



1x

33

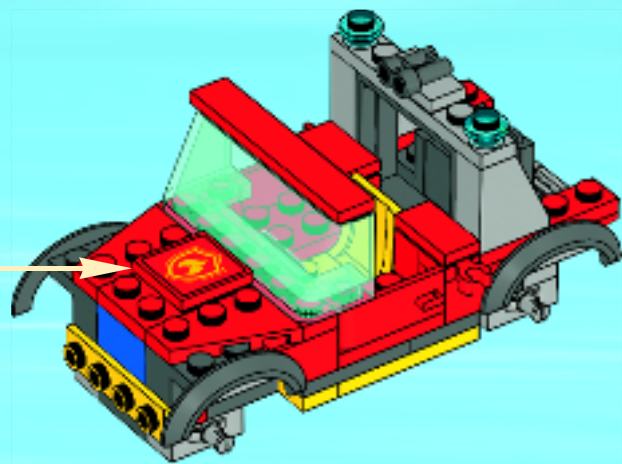
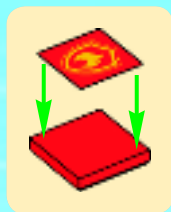

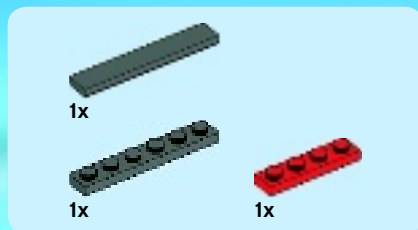

1



2

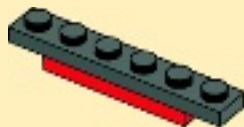

3

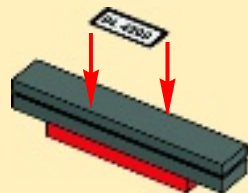

34

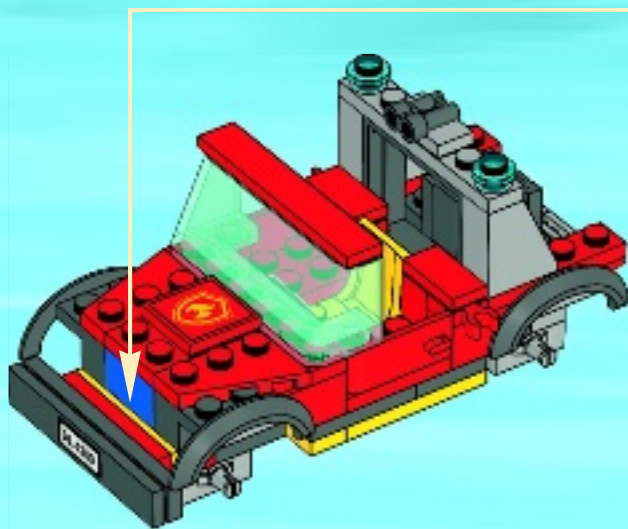



2x



2x



2x



1x



2x



1x



1x

35

1



2

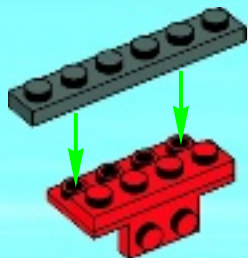

3

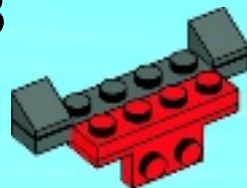

4

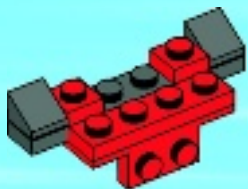

5

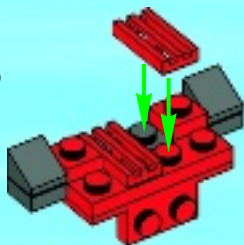

6

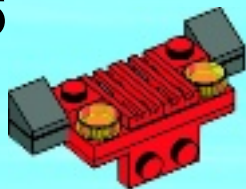

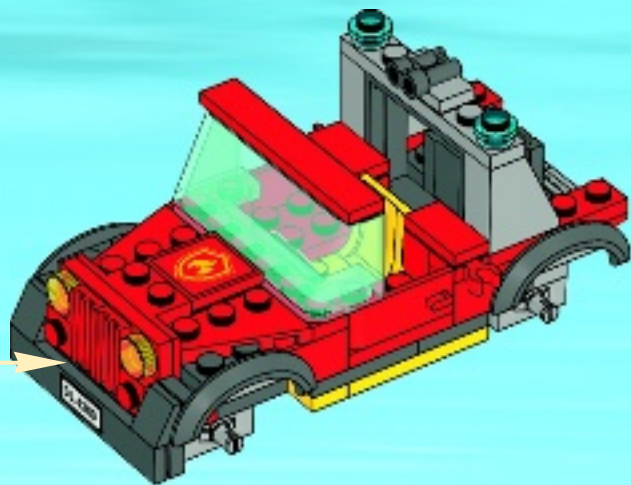



1x



1x

36

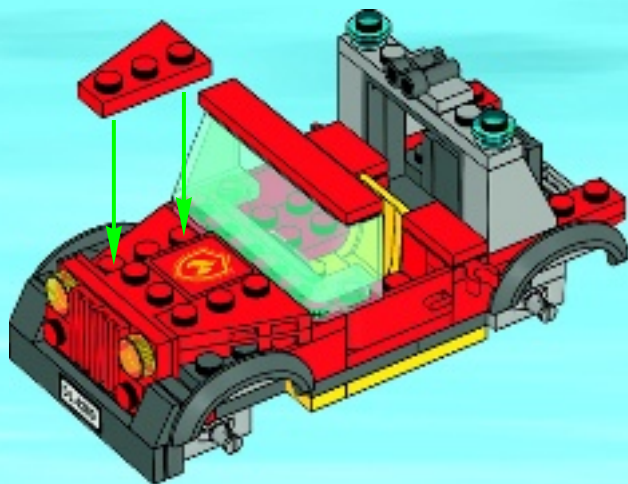



4x



4x

37

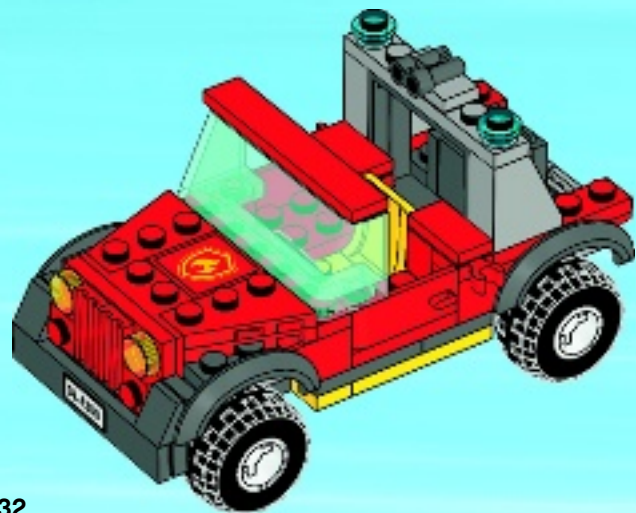

32



1x



1x

38

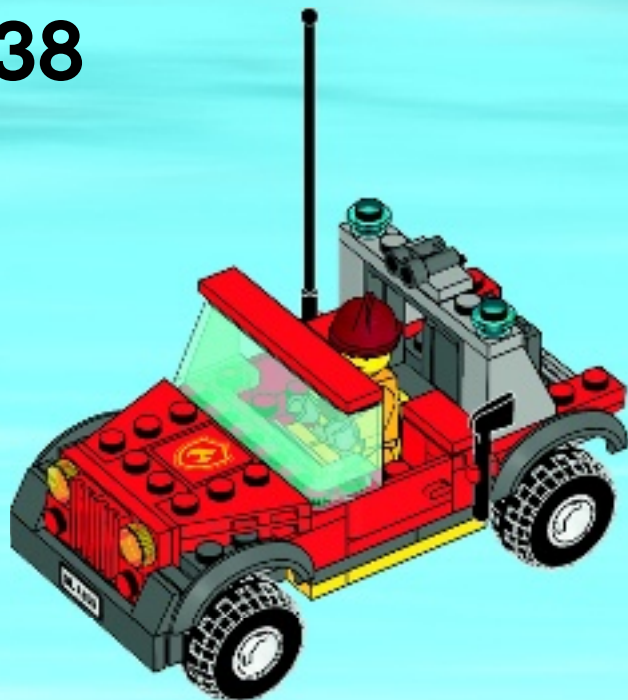



1x



1x

1

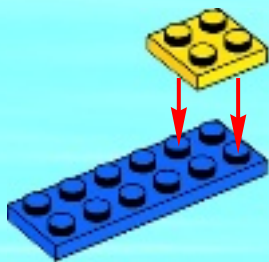

1x



2x

2

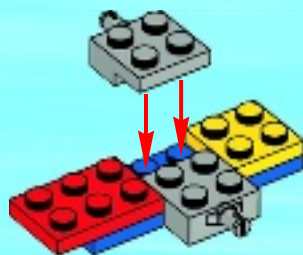



1x

3





2x



1x

4



1x



1x

5

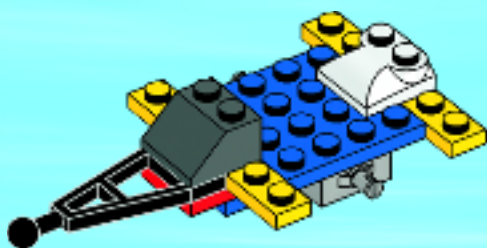



4x

6

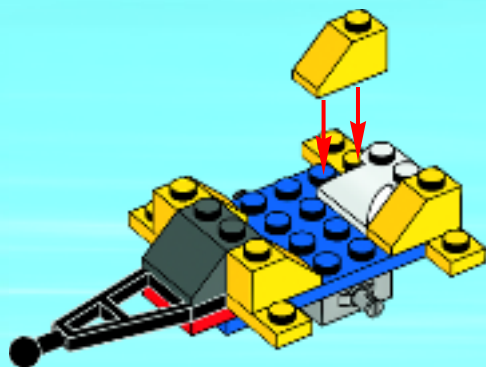



1x



2x



1x

7

1

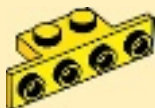

2

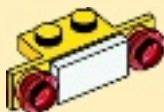

3





4x

8

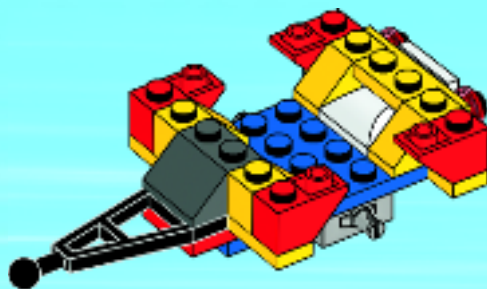



2x

9

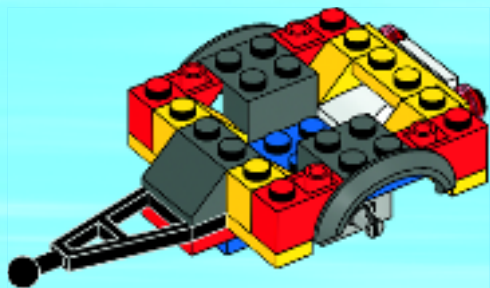

1x

10

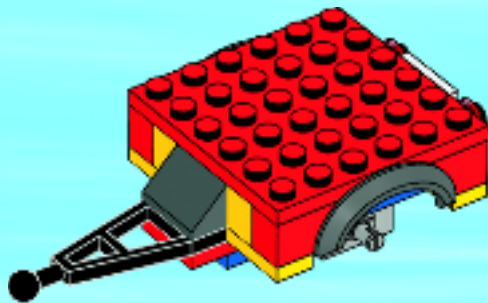



1x



1x

11

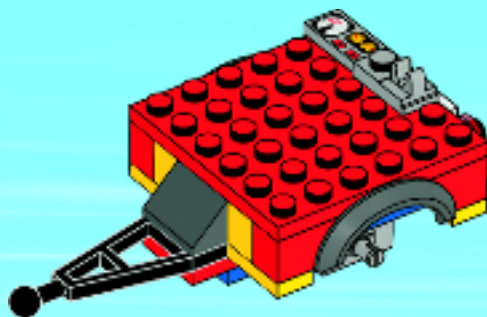



1x



2x

12

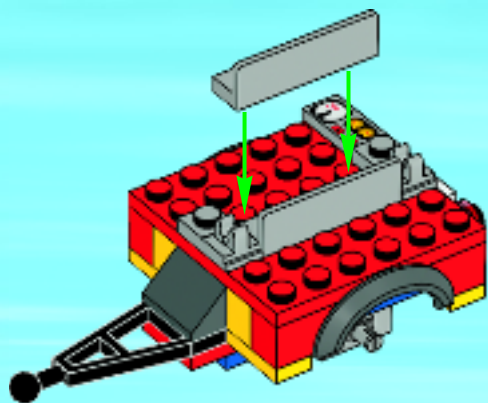

1x



1x



1x

13

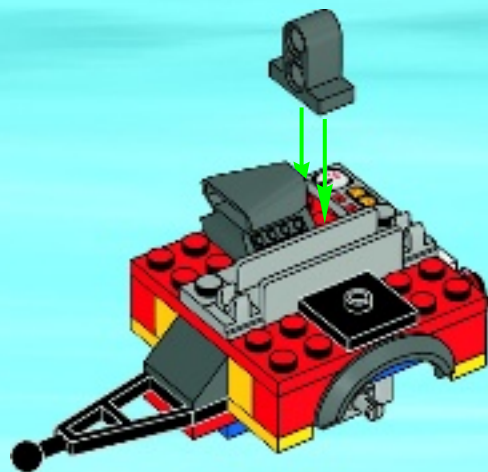

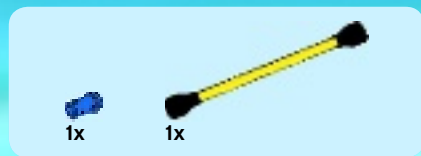

14

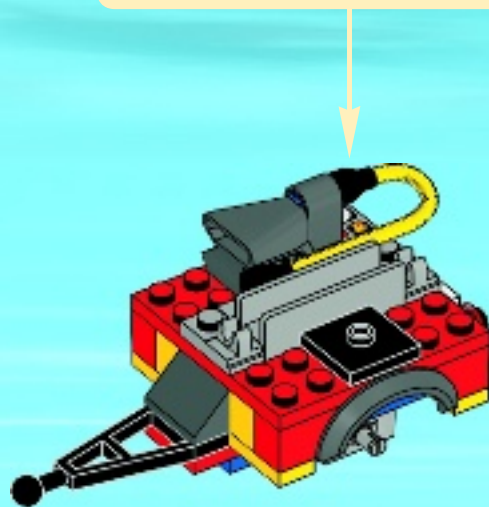
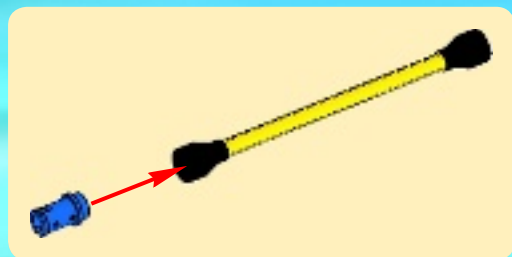

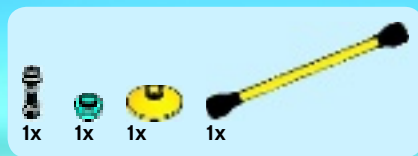

15

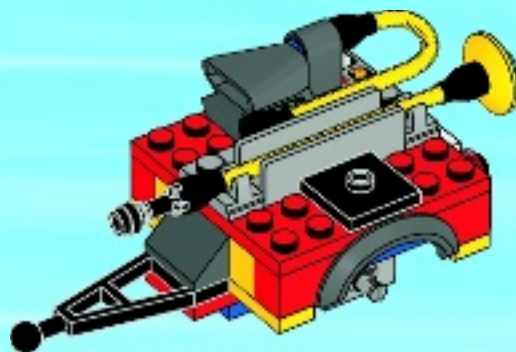
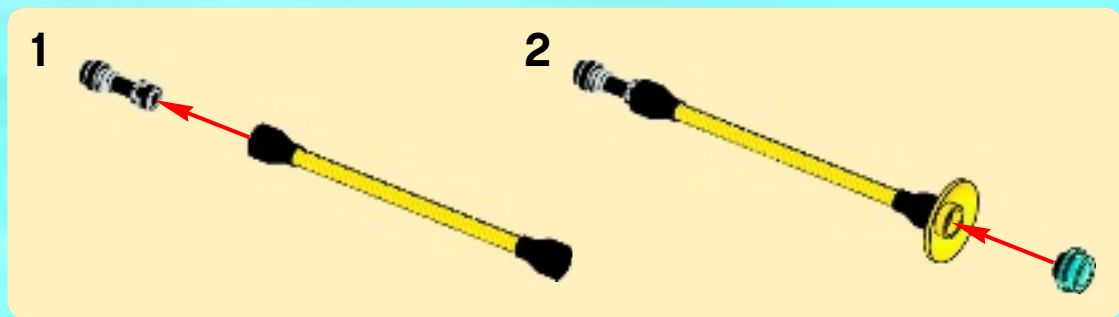



1x



1x



1x



2x

16

1

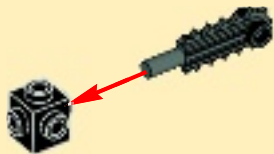

2

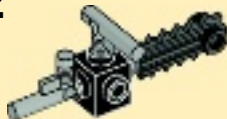

3

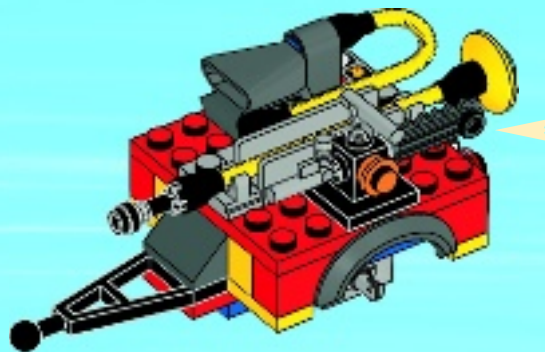



2x



2x

17



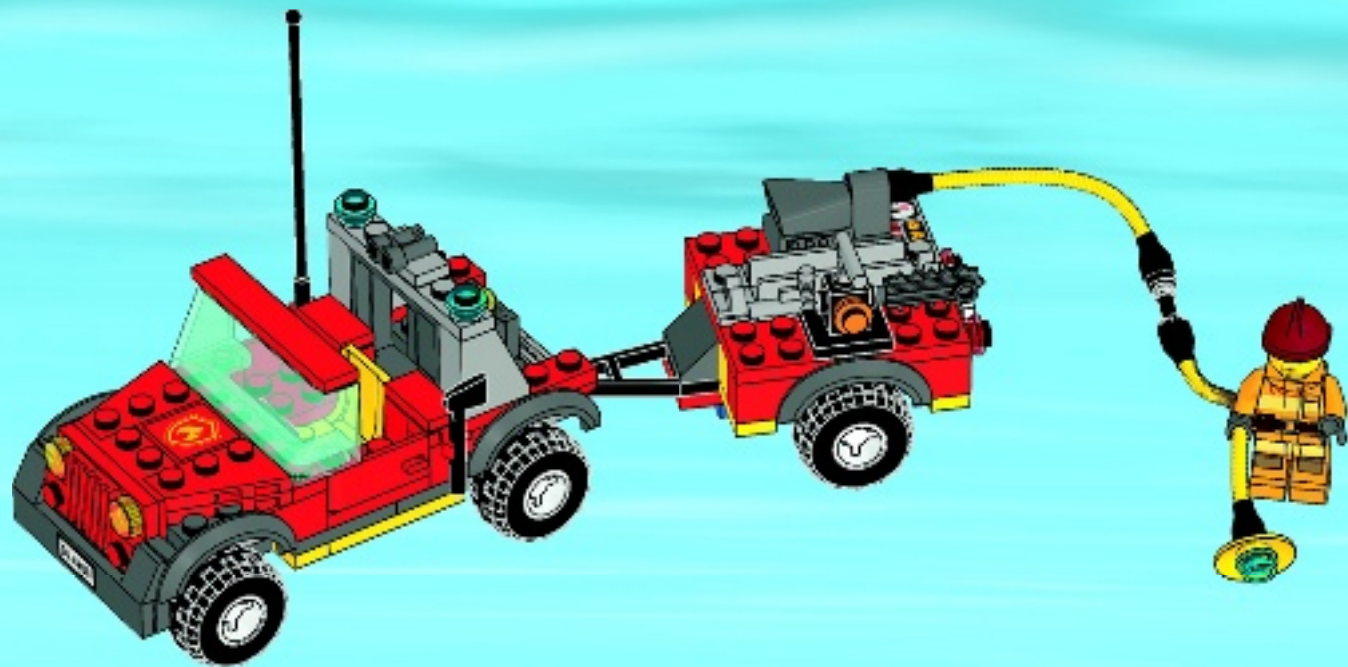



4x

3

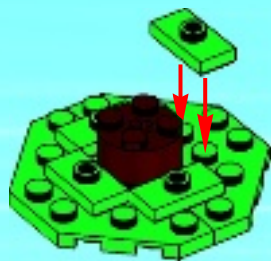

4x

4





1x

5

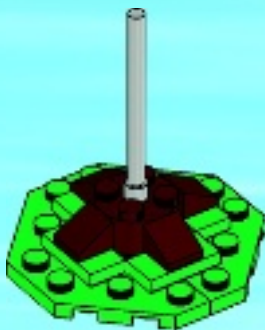

3x

6

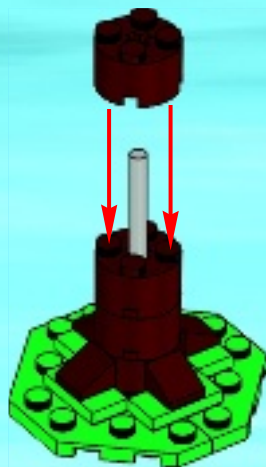



1x

7



4x

8

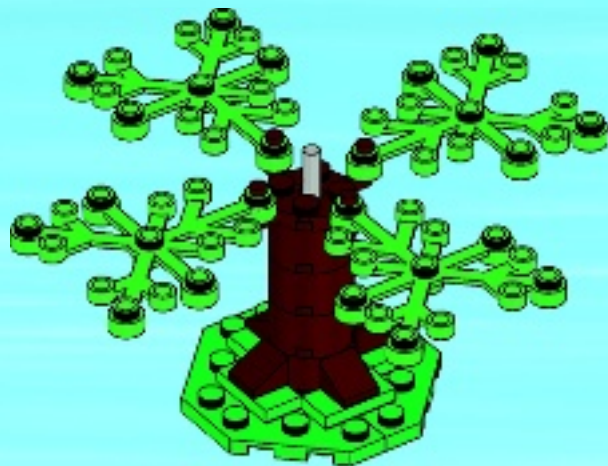



2x

9

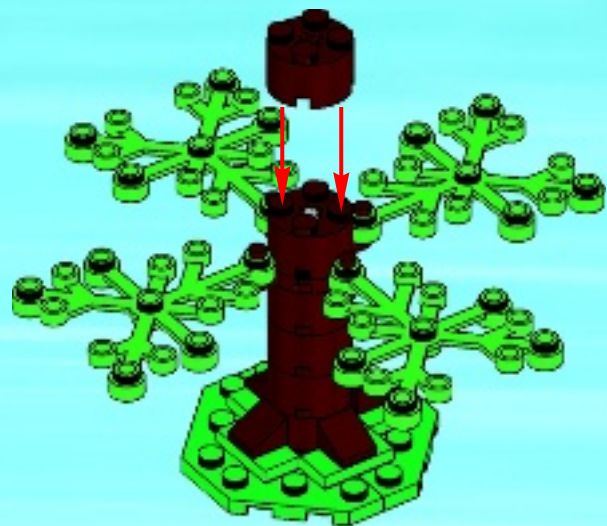

1x

10

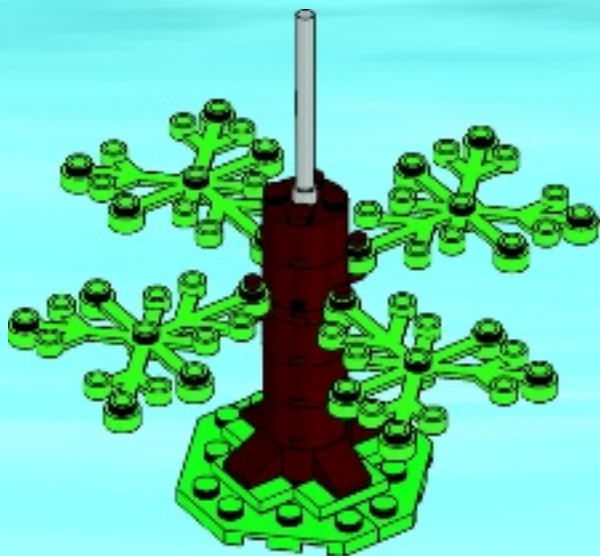



11

1



2

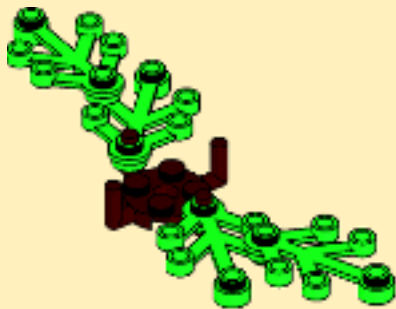

3





2x

12

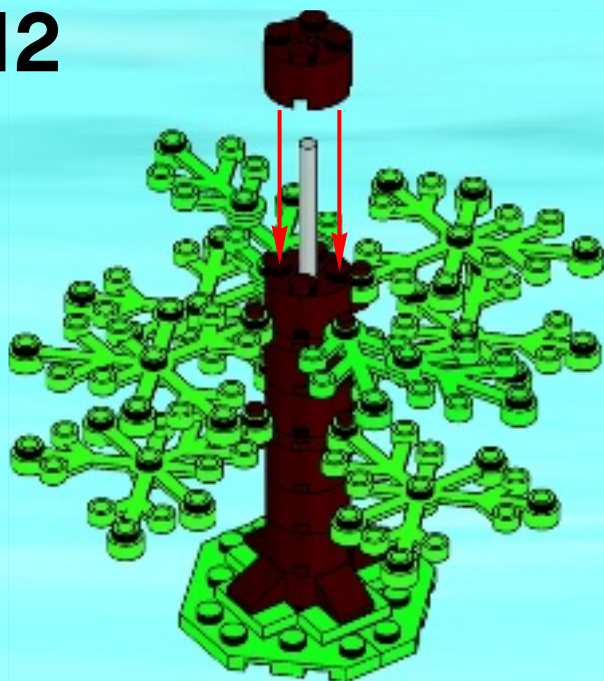



1x



4x

13

1



2



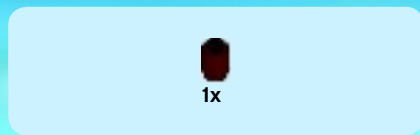

14

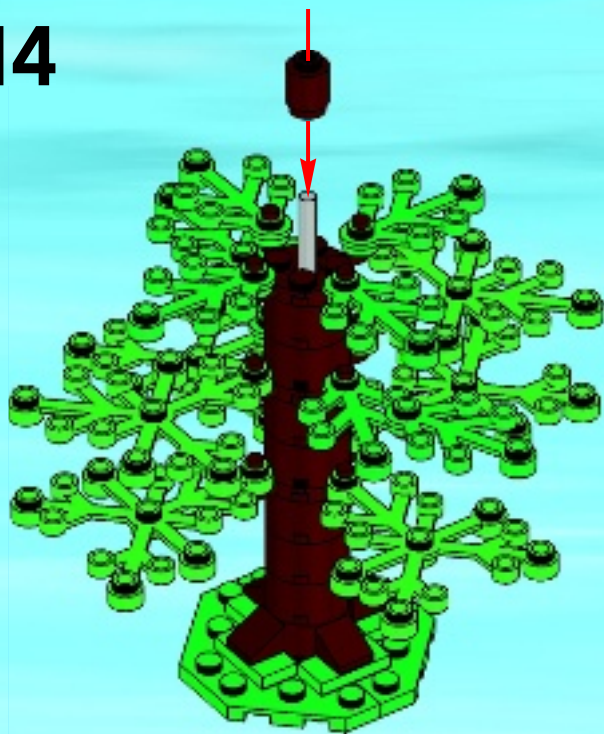



1x

15

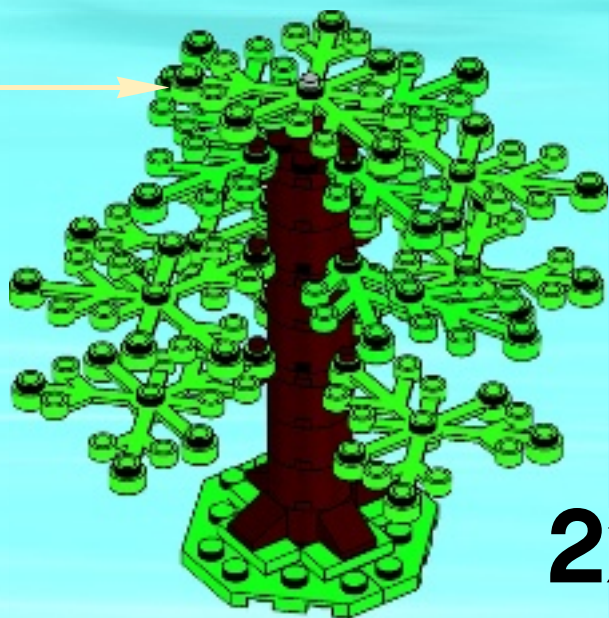

2x



10x

16



10x

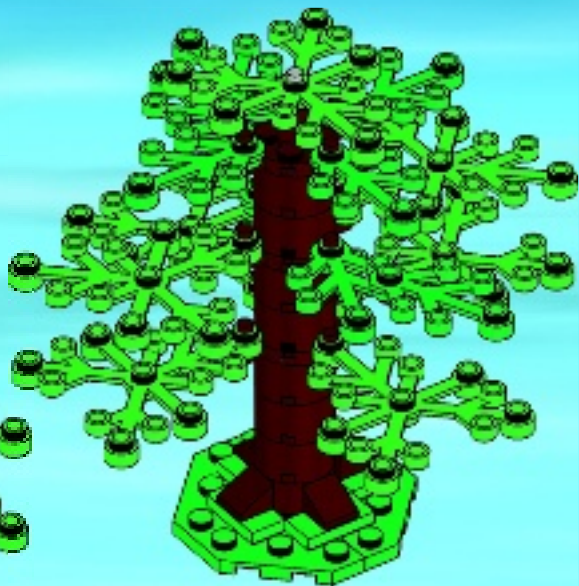



CITY



4209



4208



4427



www.LEGOclub.com



LEGO® Club Email



LEGO® Club Magazine

LEGO club™

FREE! GRATIS! GRATUIT!

SIGN UP ONLINE!

www.LEGOclub.com



00800 5346 5555*



1-866-534-6258 • 1-877-518-5346

US & Canada only

Canada seulement

- * Freephone. Mobile charges may apply.
- * Numéro sans frais. Des frais peuvent s'appliquer avec les téléphones cellulaires.
- * Gebührenfrei, Kosten für Anrufe aus Mobilfunknetzen können abweichen.
- * Gratis telefoonnummer vanaf vaste lijn.
- * Det er et gratis nummer, når du ringer fra fasttelefon.
- * Det är gratis, när du ringer från en fast telefon.
- * Numéro sans frais. Des frais peuvent s'appliquer avec les téléphones portables.



WIN!

Go to www.LEGOsurvey.com/product to fill out a survey for a chance to win a cool LEGO® Product.

No purchase necessary.

Open to all residents where not prohibited.



www.LEGOsurvey.com/product

GEWINNE!

Nimm an der Umfrage auf www.LEGOsurvey.com/product teil und hab die Chance ein cooles LEGO® Produkt zu gewinnen!

Die Teilnahme am Gewinnspiel führt zu keinerlei Kaufverpflichtungen. Teilnahme in allen nicht ausgeschlossenen Ländern möglich.

WIN!

Ga naar www.LEGOsurvey.com/product, vul een enquêteformulier in en maak kans op een cool LEGO® product.

Geen aankoopverplichting. Iedereen mag deelnemen, uitgezonderd ingezetenden van landen waar een enquêteverbod geldt.

GAGNE!

Visite www.LEGOsurvey.com/product pour répondre à un questionnaire et avoir une chance de gagner un produit LEGO® très cool!

Aucune obligation d'achat. Ouvert à tous les résidents des pays autorisés.

当てよう!

www.LEGOsurvey.com/product にアクセスして、アンケートにご記入ください。当選者にはレゴ®製品を差し上げます。

お買い上げの必要はありません。禁止されていない限り、すべての皆様にご利用いただけます。



www.LEGO.com

6015558

LEGO and the LEGO logo are trademarks of the LEGO Group. ©2012 The LEGO Group.